

Assembly and Installation instructions Model # HR520 2" class 3 hitch req'd

**WARNING! THIS PRODUCT IS NOT TO BE USED ON ANY TRAILER**

**PLEASE FOLLOW THESE IMPORTANT POINTS:**

- DRIVE SLOWLY WHEN USING THE RACK ON BUMPY OR DIRT ROADS.
- CHECK THE RACK, BIKES AND STRAPS REGULARLY DURING USE.
- IF YOU HAVE ANY QUESTIONS OR INSTALLATION PROBLEMS, PLEASE SEE YOUR RETAILER OR CONTACT US AT 800 – 747- 4085.

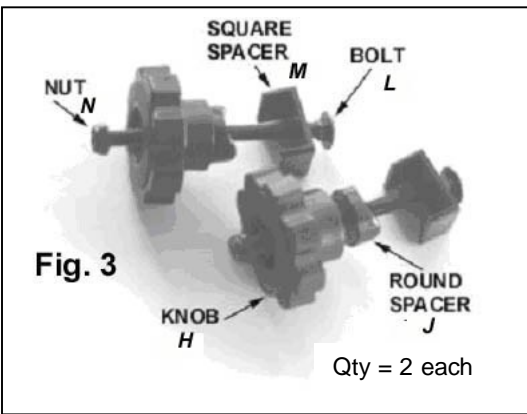
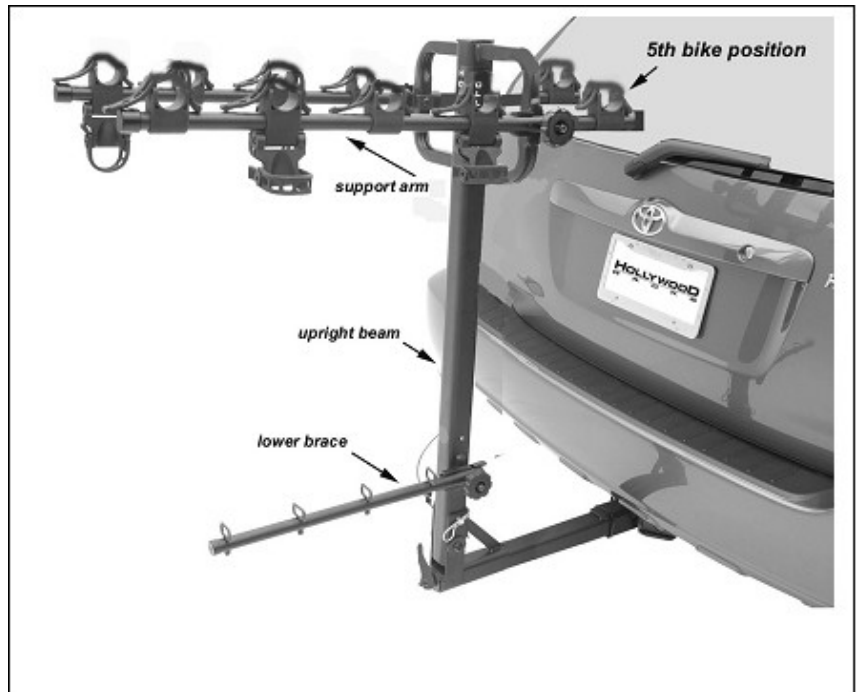
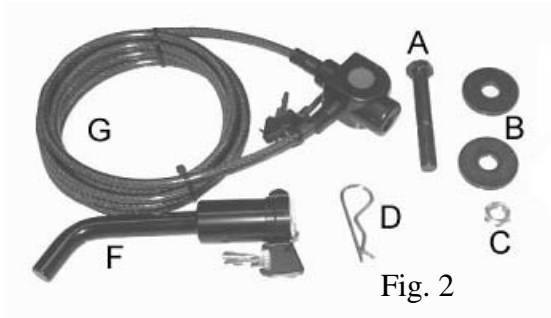
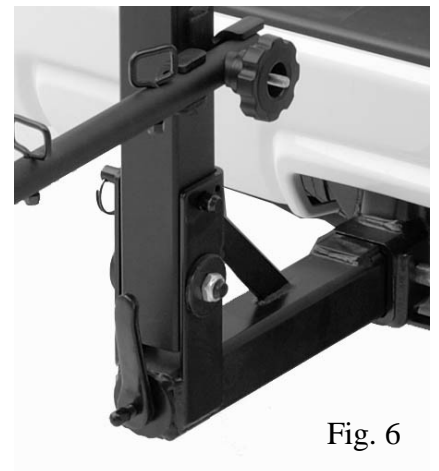
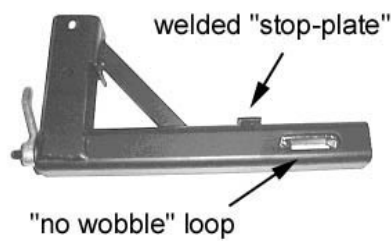
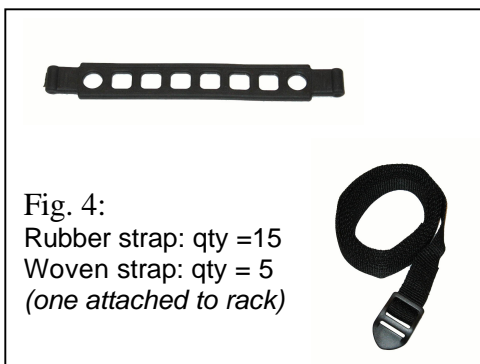

Fig. 1



After opening the box, you should have the following parts:

- Upright beam assembly (Fig 1) with wheel brace installed
- Two Support Arms (see Fig. 1)
- Parts bag including ½" diameter bolt, washers and nut, lynch pin and clip (Fig. 2: A, B, C, D).
- Locking hitch pin with security cable (Fig. 2: F & G)
- Support arm hardware bag including knob, plastic spacers and hardware (Fig. 3)
- Strap bag (Fig. 4) including 5 woven tie down straps and 15 rubber straps.
- Receiver tube assembly with "no wobble" system & handle lever (Fig. 5).

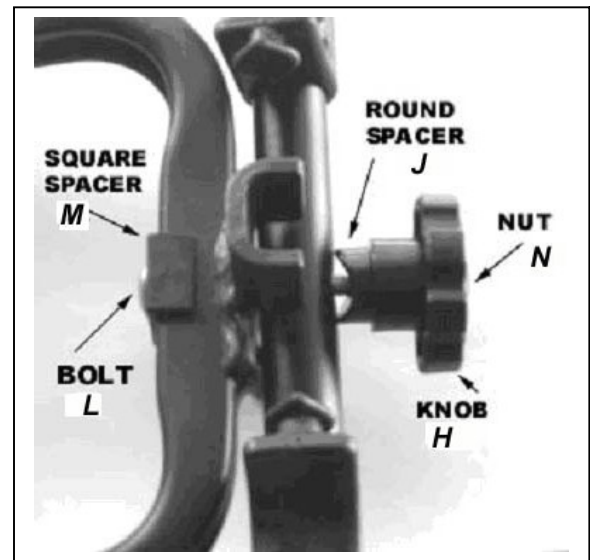

Fig. 7

## ASSEMBLY

Tools required for assembly: Two 6" adjustable wrenches or equivalent, ½"/13mm socket

The Road Runner rack is easily assembled on your workbench or any flat surface. To assemble the rack, lay the upright beam face down on the bench (Hollywood decal facing down). Place the receiver tube's bracket on to the end of the upright beam so that the insert tube is pointing up.

1. Place a washer (B) on the end of the bolt (A), then insert the bolt through the **lower** hole of this bracket and pass it through the **lower** hole of the upright tube.. Once the bolt is protruding through the other side of the bracket, install the other washer (B) and nut (C). Tighten the nut securely on the bolt. Insert the attached lynch pin through the **upper** hole, and install lynch pin clip (D) in hole at the end of the lynch pin. See Fig. 5
2. To install the support arms: Locate parts bag with knob assembly (includes knob, carriage bolt, square spacer, round spacer and nut). Insert the bolt L through the square spacer M, then through the bike rack frame and support arm. Then install the round spacer J and knob H. Tighten knob, then install the nut N on the very end of the bolt so that the nut's nylon lock catches the bolt end. Repeat for other side. See Fig. 7 Note: Nut requires ½" or 13mm socket wrench for tightening.

## INSTALLING THE RACK ON YOUR VEHICLE:

3. Within the parts bag, please locate the Locking Hitch Pin (F).
4. When inserting the rack into the trailer hitch, try to get the receiver tube as parallel to the hitch as possible. Slide the rack in a couple of inches until the welded "stop-plate" on the top of the receiver tube makes contact the outer face of your vehicle's hitch.
5. Unlock the Locking Hitch Pin and insert the long end through the trailer hitch **and** receiver tube. Be certain that the hitch pin goes through the "loop" at the end of the "no wobble" internal threaded rod. Failure to do so will render the "No Wobble" system inoperable. Be sure to install the lock onto the end of the Locking Hitch Pin. **Failure to do so will result in an accident.**
6. Tighten the lever clockwise to engage the patented "No Wobble" system, which will eliminate the movement of the insert tube in the receiver. **The lever should be turned "up" or to the side after tightening to prevent it from being damaged in the case you have to descend a steep driveway or have some other close encounter with "Solid Ground."** The rack should now be attached to your vehicle, and locked into place.

## INSTALLING BIKES ON THE RACK:

7. Back off the knob on the rack's support arms, pull out the support arms and rotate them into the horizontal position. The arms should fit into the welded steel channels. Retighten the knobs securely. Rotate lower brace to its horizontal position.

8. Loosen knob on lower brace then rotate lower brace to its horizontal position. It should fit in the welded steel channel. Retighten black knob.

9. For ease of installation, we suggest you put the bigger bikes on the inside (closest to vehicle), smaller frames or kids bikes on the outside. The first bike loaded should have the handlebars facing towards the driver's side of the vehicle. If carrying five bikes, load the first bike in the position between the upright beam and vehicle.

10. Place the top tube (or closest appropriate frame tube) onto the bike cradles, install the straps over the bike tube and attach to the anchor tabs on both sides of the cradle. Use a strap notch-hole that provides a snug fit, but take care not to pull the strap over-tight. This can put undue stress on the bike's paint, and may over-stretch the strap, making it more susceptible to breakage. Be sure to use the Anti-Sway blocks (below the support arms) to strap the bikes seat tube (or other frame tube as appropriate) to prevent the bikes from swaying on the **Road Runner** rack. Note Fig. 8a, 8b below for correct application of the straps on the anti-sway blocks.

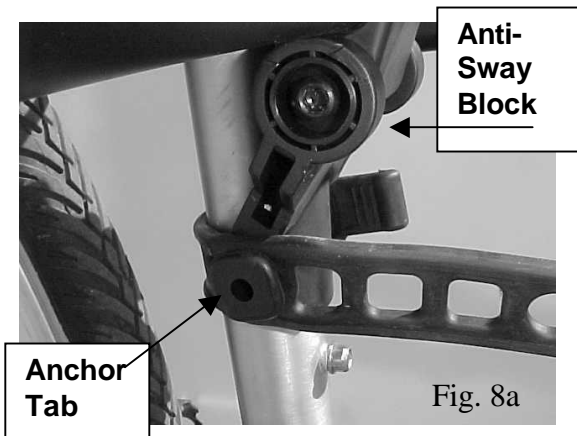

**Note:**  
Use **Anti-sway blocks** to keep bikes stable while vehicle is in motion. Be careful not to over-stress the straps!

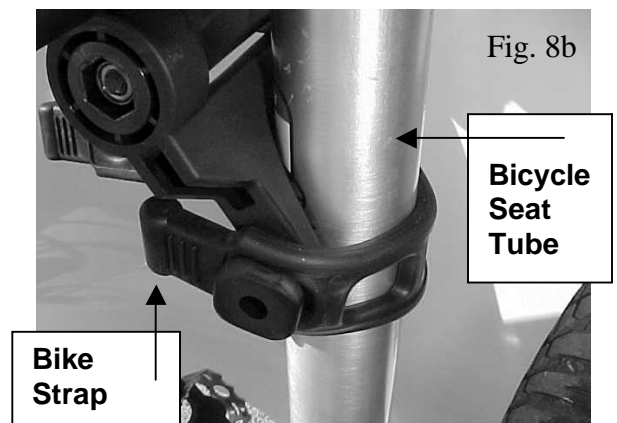

11. Using the lower brace anti-sway system (Fig. 9):

Using the 1" x 86" woven straps, run the strap through both front and rear wheels of each bike and then through the eyelet loop on the lower brace. Thread the end of the strap into the buckle and tighten the strap so that the bikes do not move. Repeat for the other bikes.



12. Installing “wrap around tie down,” and security cable: After all the bikes have been installed, take the 86” tie down strap and wrap it around the rack’s upright tube and all of the bikes. There is not a lot of room, but **this is a very important safety step**. Tighten this strap securely.

### 13. Anti –Theft Security

For anti-theft security, the rack comes with a locking hitch pin and a 9-foot cable with an integrated lock. Wrap the cable around the bike frames, their wheels and through the rack. Secure by inserting end of cable in the lock.

### 14. REMOVING THE BIKES AND RACK

To remove the bikes, simply undo the straps and gently lift the bikes off. If you’re in a parking lot, be sure to fold down the support arms and fold up the wheel brace so as to minimize the length of the rack when not in use. To remove the rack from the vehicle, fold the support arms and lower brace, and remove the Locking Hitch Pin. Unscrew (counter-clockwise) the “no wobble” lever and slide the rack out of the hitch receiver.

### 15. BACKING OUT OF DRIVEWAYS AND GOING OVER BUMPS

Please keep in mind that when transporting bikes, you will be carrying more weight on your hitch. This means the rear of your vehicle will be lower to the ground. When going up driveways or over bumps, drive slowly and at an angle if possible. If you have a car or minivan where the hitch is low to the ground, the rack may hit the ground. Go slowly and please be sure the handle lever for the no wobble system is turned up or to the side.

#### **Limited Lifetime Warranty (effective January 1, 2008):**

Hollywood Racks will warrant its car racks and accessories during the time that an original retail purchaser owns the product subject to the exclusions and limitations of this warranty. Hollywood Racks will remedy defects in materials and workmanship by repairing or replacing (at its option) a defective part or the complete rack without charge for labor or parts. Hollywood Racks may elect (at its option) to issue a refund equal to the purchase price paid for the product.

This warranty does not cover problems caused by normal wear and tear including (but not limited to) weather, scratches, dents, rust, accidents, unlawful vehicle operation, misuse, abuse, neglect, theft, unauthorized modifications, or unauthorized repair. No warranty is given for defects resulting in incorrect assembly, incorrect installation onto the vehicle, installation on a “no fit” vehicle, incorrect attachment of bicycles onto the rack, or overloading of the rack’s weight restrictions. This warranty terminates if the original retail purchaser transfers the product to any other person. If a product is believed to be defective, the original retail purchaser should contact either the original retailer or Hollywood Racks directly at 800-747-4085 or at [info@hollywoodracks.com](mailto:info@hollywoodracks.com)

**Disclaimer of Liability:** Repair or replacement of a defective product or the issuance of a refund or credit (as determined by Hollywood Racks) is a purchaser’s exclusive remedy under this warranty. Damage to a purchaser’s vehicle, cargo, bicycles and or to any other person is excluded. This warranty is expressly made in lieu of any and all other express warranties, whether oral or written.

Hollywood Racks shall not be liable for any direct, indirect, consequential, incidental, special, punitive or any other damages in connection with the purchase, use or handling of this product.

Some states do not allow the exclusion or limitation of consequential or incidental damages and the above limitation may not apply to you. This warranty gives you specific legal rights and you have other rights, which vary from state to state.

## **Hollywood Racks**

**12812 S. Spring St. Los Angeles, CA 90061**

**(800) 747-4085 or (310) 516-8600 FAX (310) 516-8955 [info@hollywoodracks.com](mailto:info@hollywoodracks.com)**

**[www.hollywoodracks.com](http://www.hollywoodracks.com)**

**Customer Service: M-F 8:00 AM – 3:00 PM PST**

**Made in Taiwan 022008 rev c**

# Hollywood Road Runner 5. Instructions d'assemblage et d'installation

## Modèle HR520

Attention! Ne jamais monter ce produit sur une remorque ou un véhicule remorqué

### Suivre les directives suivantes:

**Conduire doucement sur chaussée en mauvais état ou chemin de terre.**

**Vérifier le porte-vélo, les vélos et les sangles régulièrement pendant utilisation.**

Après avoir ouvert la boîte, vous trouverez les pièces suivantes:

- Poteau central (Fig 1) avec bras inférieur installé.
  - Sachets de pièces contenant boulons, rondelles, écrou et agraffe (Fig.2:A,B,C,D)
  - Cheville de verrouillage et câble de sécurité (Fig. 2; F & G)
  - Boulonnerie pour bras de supports, mollettes et pièces plastique rond et carré Fig. 3.
  - Sachet de pièces contenant. Sangle d'attache (caoutchouc et nylon) Fig. 4.
- Note: Road Runner 5 possède 15 sangles en caoutchouc et 5 sangles en nylon.
- Tube pour l'attelage remorque avec le système anti-jeu et levier Fig. 5.

Assemblage: Outils nécessaire: Clefs à mollettes de 6" ou équivalent

Le Road Runner est facilement assemblé sur une surface plate. Pour assembler le porte-vélo, poser le Poteau vertical (Fig 1) à plat, face vers le bas (Hollywood decal vers le bas). Placer le tube pour attelage (Fig 4) à l'extrémité du Poteau principal (Fig 1) de façon à ce que le tube pour attelage soit perpendiculaire au Poteau.

Place une rondelle B au bout du boulon A, ensuite insérer le boulon A à travers le trou inférieur sur le tube de l'attelage Fig.4 et le trou inférieur du Poteau vertical Fig 5. Une fois que le boulon a traversé de l'autre côté du tube pour attelage, installer l'autre rondelle B et l'écrou C. Serrez fermement le boulon et l'écrou à l'aide d'une clef de 3/4" ou d'une clef à mollettes. Insérer la broche (sur le Poteau vertical) à travers le trou supérieur du tube de l'attelage et à travers le Poteau vertical et de l'autre côté du tube de l'attelage. Installer l'agraffe D dans le trou de la broche.

Pour installer les bras de support, insérer le boulon L (Fig. 3) dans la pièce en plastique carré M, ensuite dans le trou du cadre principal comme sur la Fig. 7. Installer ensuite la pièce en plastique ronde J et la molette H. Serrer la mollette, installer ensuite l'écrou N à l'extrémité du boulon jusqu'à ce que le nylon de l'écrou prenne. Répéter de l'autre côté Fig. 7.

### Installer le porte vélo sur votre véhicule.

Trouver la cheville verrouillage F.

Insérez le porte vélo dans l'attache remorque. S'assurer que le tube pour attelage pénètre jusqu'à qu'il touche la "plaque-stop" soudée sur le tube Fig. 4.

Ouvrir la cheville verrouillage F et insérer la partie longue à travers le trou de l'attelage remorque ET le tube pour attelage du porte-vélo. S'assurer que la cheville passe à travers la "boucle" à l'extrémité du pas de vis du système anti-jeu. De ne pas traverser la "boucle" rend le système inopérable. S'assurer d'installer le verrou de l'autre côté de la cheville F. **De ne pas verrouiller pourrait causer un accident.**

Serrer le levier (fig 5) dans le sens des aiguilles d'une montre pour engager le système breveté Anti-Jeu, qui élimine tous mouvements. Le levier devrait être toujours dans une position vers le haut pour le protéger au cas où vous descendez une allée pentue. Le porte-vélo devrait être maintenant attaché sur votre véhicule et verrouillé.

## Installer les vélos sur le porte-vélo.

1. Deserrer les mollettes de chaque côté des bras de supports, et faire pivoter les bras de supports dans une position horizontale ou d'utilisation dans les pièces soudées sur chaque côté. Reserrer les mollettes fermetures. Dévisser la molette de la barre inférieure (Fig 6) et faire pivoter en position horizontale. La barre doit être dans la pièce soudée sur le Poteau central. Reserrer la molette.

2. Attacher les sangles de caoutchouc aux berceaux porteurs sur les bras de support à travers un trou rond à l'extrémité de la sangle avant de monter les vélos. Attacher les sangles des berceaux du côté du véhicule seulement.. Placer le vélo le plus lourd en premier ( le plus proche du véhicule), en mettant le tube supérieur du cadre sur les berceaux en caoutchouc. Le guidon doit être du côté du conducteur. Attacher fermement les 3 sangles en caoutchouc Fig. 8a et 8b. Répéter les mêmes instructions pour le (s) prochain vélo (s) en le mettant dans l'autre sens (guidon vers le passager)

3. Utiliser la barre inférieure (Fig 6) anti-balancement:

Passer les sangles de 86" à travers les oeillets et les 2 roues de chaque vélo. Attacher avec la boucle et serrer la sangle de façon à ce que chaque vélo ne bouge pas (Fig 9).

4. Attacher une sangle d'attache des vélos de 86" et sécurité.

***Important: Après que tous les vélos soient bien installés, attacher la dernière sangle de 86" autour du Poteau vertical ET de tous les vélos. Serrer fermement.***

5. Système de sécurité. Attacher tous les vélos au porte-vélo à l'aide du câble G de sécurité de 9'insérer l'embout du câble dans le trou de la serrure.

6. Pour incliner le porte-vélo, enlever l'agrafe D et la goupille du Poteau central, et aider le Poteau central à s'incliner gentillemeent pour accès à l'arrière du véhicule.

Important:

Le fabricant de ce produit n'est pas responsable des dommages causés par le mauvais usage de ce produit. C'est la responsabilité de l'utilisateur de s'assurer que le porte vélo est monté proprement sur le véhicule et que les vélos soient proprement chargés sur

le porte vélo comme décrit dans ces instructions d'installation.