



RHINO-RACK

Aerodynamic & Heavy Duty Roof Rack Systems

Rhino Luggage Bag

Half(LBH), Small(LBS), Medium(LBM), Large(LBL), Extra Large(LBXL).

Note: Please read these instructions carefully prior to installation.
Please refer to your fitting instruction to ensure that the roof racks are installed in the correct locations.
Check the contents of kit before commencing fitment and report any discrepancies.
Place these instructions in the vehicle's glove box after installation is complete.

IMPORTANT:

The Luggage Bag is only to be mounted onto a Rhino Roof Basket or Rhino Alloy Tray, NOT directly to the cross bars or directly onto the vehicle roof.

The Luggage Bag is designed to carry light bulky items only. It is NOT to be used for carrying heavy items such as; BBQ gas bottle, spare wheels, high lift vehicle jack etc.

Sharp objects must be properly wrapped and secured so as not to puncture the Luggage Bag.

Wash the Luggage Bag with a non petroleum based detergent such as dishwashing liquid or car wash. Never use a scourer or wire brush on the Luggage Bag.

To minimise the chance of water and dust entering the Luggage Bag ensure the velcro strip in front of the zipper is sealed the whole way around.

WARRANTY

MISUSE OF THE PRODUCT BY NOT FOLLOWING THESE RECOMMENDATIONS WILL VOID YOUR WARRANTY.

Recommendations;

It is essential that all strap and bolt connections be checked after driving a short distance when you first install your Rhino Rack accessory. Connections should be checked again at regular intervals (probably once a week is enough, depending on road conditions, usage, loads and distances travelled). You should also check the cross bars and accessories each time they are refitted. Make sure to fasten your load securely.

Please ensure that all loads are evenly distributed and that the centre of gravity is kept as low as possible.

Use only non-stretch fastening ropes or straps.

Sensitivity to crosswinds, behaviour in curves and braking.

The handling characteristics of the vehicle, changes when you transport a load on the roof. For safety reasons, we recommend you exercise extreme care when transporting wind-resisting loads; special consideration must be taken into account when braking.

Please remove cross bars and luggage bag when putting vehicle through an automatic car wash.

Load Ratings.

Refer to vehicle manufactures carrying capacity for cross bars. When cross bars are to be used in off-road conditions, please build a safety factor of 1.5 into this load limit. Although the roof racks are tested and approved to AS1235-2000, Australian road conditions can be much more rigorous. However, increasing the number of cross bars does not increase the vehicles maximum permissible roof loading.

Note for Dealers and Fitters.

It is your responsibility to ensure instructions are given to the end user or client.

Rhino-Rack
3 Pike Street, Rydalmere,
NSW 2116, Australia.
(Ph) (02) 9638 4744
(Fax) (02) 9638 4822

Document No: RS-142
Prepared By: Craig Jones
Authorised By: Gary England

Issue No: 03
Issue Date: 30/06/2008

These instructions remain the property of Rhino-Rack Australia Pty Ltd and may not be used or changed for any other purpose than intended.



Rhino Luggage Bag - LBH, LBS, LBM, LBL, LBXL.

1

Medium Bag (LBM) shown.

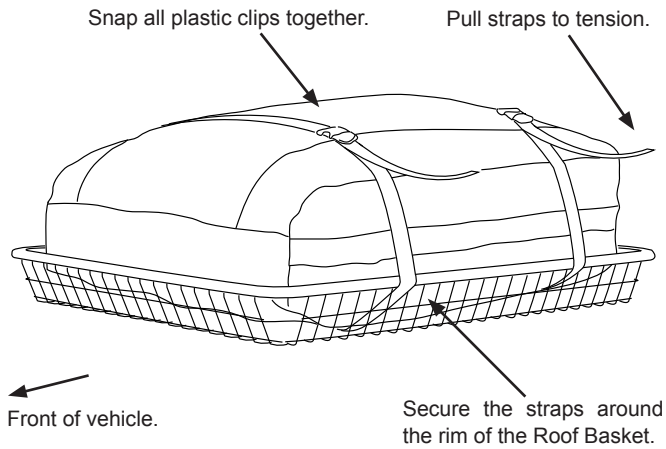

Roof Basket fitment:

- Place the Luggage Bag onto the Roof Basket with the opening to the rear of the vehicle. Unzip the bag to add items inside. Zip the bag up and press the velcro stripping together.
- Secure the bag to the basket by threading the external straps through the basket and around the outer rim of the basket. Snap the plastic clips together. Pull the straps to put tension on the load.
- Additional straps should be used to secure odd shaped loads.

2

Large Bag (LBL) shown.

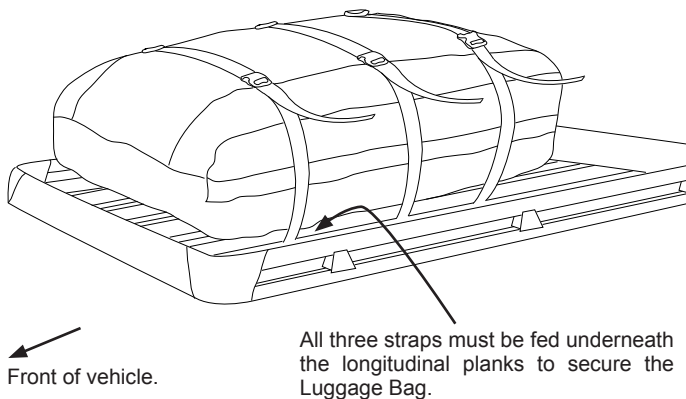

Alloy Tray fitment:

- Place the Luggage Bag onto the Alloy Tray with the opening to the rear of the vehicle. Unzip the bag to add items inside. Zip the bag up and press the velcro stripping together.
- Secure the bag to the Alloy Tray by threading the external straps under the longitudinal planks. Snap the plastic clips together. Pull the straps to put tension on the load.
- Additional straps should be used to secure odd shaped loads.

3

Extra Large Bag (LBXL) shown.

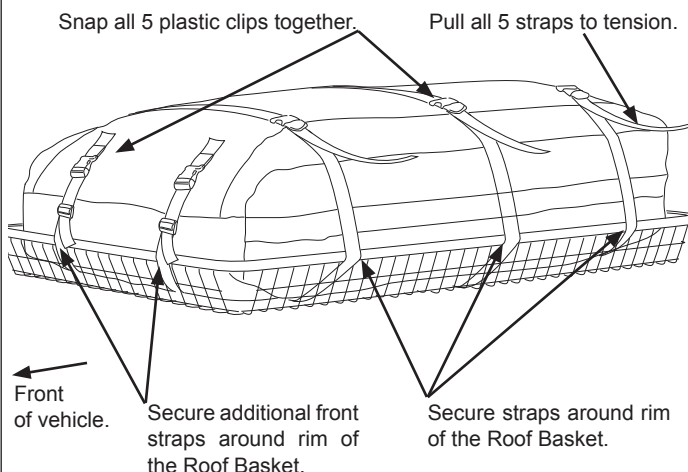

Extra Large Luggage Bag (LBXL):

- Place the Luggage Bag onto the Roof Basket or Alloy Tray with the opening to the rear of the vehicle. Unzip the bag to add items inside. Zip the bag and press velcro stripping together.
- Secure the side straps as described in step one & two.
- Two additional straps are attached to the front.
- **For the Roof Basket** secure the front two straps around the front rim of the basket.
- **For the Alloy Tray** secure the front two straps around the front railing of the tray.
- Additional straps should be used to secure odd shaped loads.