

Assemble M6 x 35mm bolt, M6 spring washer, M6 square washer, spacer block and M6 square nut. Slide legs onto crossbar and finger tighten bolt.

3

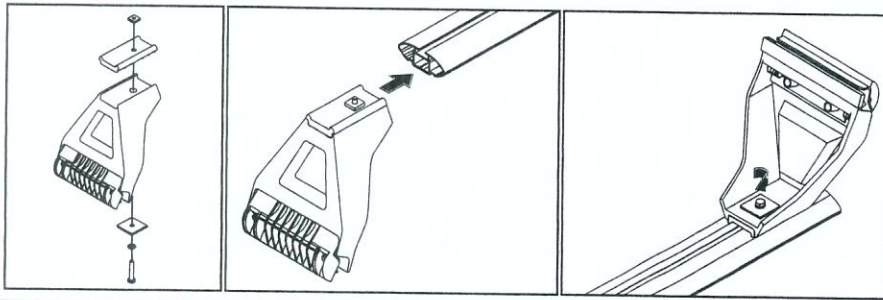

Insert the rubber buffer strip fully into the crossbar. Check the rubber buffer strip is fully inserted.

4

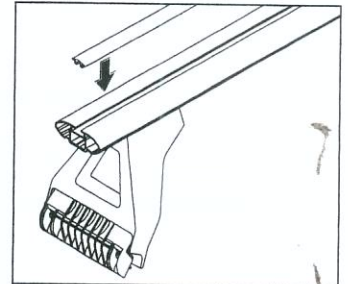

When the leg assemblies are fitted to the vehicle, then tighten M6 bolts to 3-4Nm. **Do not over tighten.** Measure slot length (A) and (B). Cut a piece of the underside strip and locate into the slots.

5

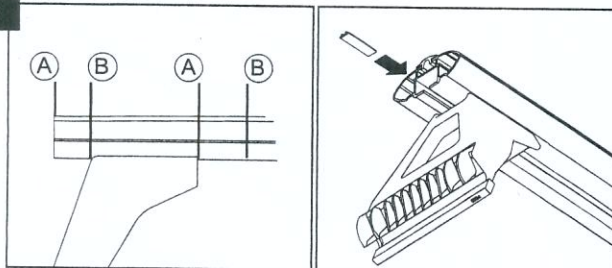

Insert the end cap completely into the crossbar.

6

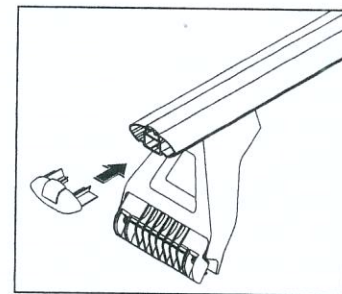

Important Information

RECOMMENDATIONS

Please refer to your vehicle manufacturers operating manual for maximum roof load rating.

It is essential that all bolt connections be checked after driving a short distance when you first install your Rhino "Aero" Bar.

Bolt connections should be checked again at regular intervals (probably once a week is enough, depending on road conditions, usage, loads and distances travelled). You should also check the roof bars each time they are refitted.

Crossbars and accessories should be cleaned and all screw threads should be lubricated at regular intervals.

Rhino-Rack offers a 3 year warranty to the original purchaser of the Rhino "Aero" Bar and Accessories.

Rhino-Rack cannot be held responsible for incorrect mounting of the roof rack system or for usage that exceeds vehicle and production tolerances.

Make sure to fasten your load securely.

Please ensure that all loads are evenly distributed and that the centre of gravity is kept as low as possible.

USE ONLY NON-STRETCH FASTENING ROPES OR STRAPS.

SENSITIVITY TO CROSSWINDS, BEHAVIOUR IN CURVES AND BRAKING

The handling characteristics of the vehicle change when you transport a load on the roof. For safety reasons, we recommend you exercise extreme care when transporting wind-resisting loads; special consideration must be taken into account when braking.

PLEASE REMOVE CROSSBARS WHEN PUTTING VEHICLE THROUGH AN AUTOMATIC CAR WASH

LOAD RATINGS

The vehicle manufactures recommended load rating is the maximum permissible load per pair of roof racks (include the weight of the roof rack, 5kg). When roof bars are to be used in extreme off-road conditions please build a safety factor of 1.5 into this maximum load limit. Although roof bars are tested and approved to AS1235-2000, Australian road conditions can be much more rigorous.

NOTE FOR FITTERS AND DEALERS

It is your responsibility to ensure instructions are given to the end user or client.

Rhino-Rack

3 Pike Street, Rydalmere,
NSW 2116, Australia.

(Ph) (02) 9638 4744 (Fax) (02) 9638 4822

Document No: RR-112

Prepared By: Sheila Oliveira

Authorised By: Gary England

Issue No: 01

Issue Date: 11/06/2004

These instructions remain the property of Fetovu Pty Ltd T/as Rhino-Rack and may not be used or changed for any other purpose than intended.



RHINO-RACK

Aerodynamic & Heavy Duty Roof Rack Systems

Rhino Heavy Duty - "Aero" Bar To Suit RL110, RL150, RL210, RL280, RLTP & RLTF Legs

Place these instructions in the vehicle's glove box after installation is complete.

Important: Please read these instructions carefully prior to installation.
Please refer to your fitting instruction to ensure that the roof racks are installed in the correct locations.
Check the contents of kit before commencing fitment and report any discrepancies.

Parts List

Item	Component Name	Qty.	Part No.
1	Rubber Buffer	1	R011
2	Aero Bar	1	A224
3	Aero R3000 End Cap	2	M153
4	Underside Strip	1	R012
5	M6 Square Nut	2	N035
6	Spacer Block	2	M154
7	M6 Square Washer	2	W037
8	M6 Spring Washer	2	W004
9	M6 x 35mm Hex Head Bolt	2	B100
10	Fitting Instruction	1	RR112

Layout

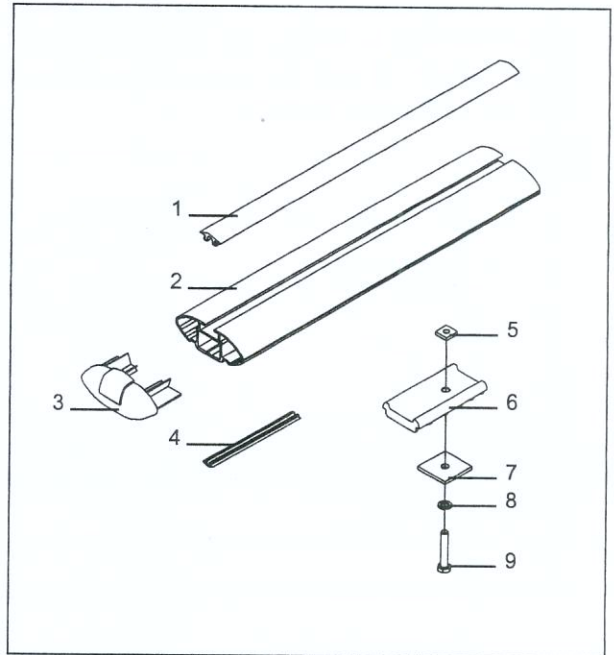
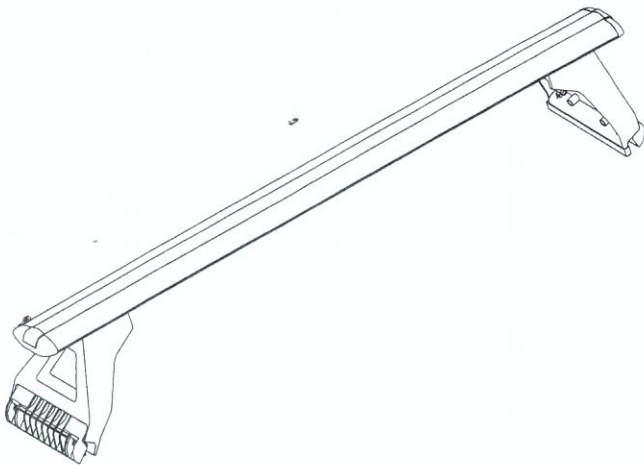

Care Instruction

Wash and clean vehicle roof prior to installation.

Note

Crossbar suits all Heavy Duty track and gutter mount legs.

Tools Required

10mm Spanner
Stanley knife
Tape measure

Remove all leg hardware from the top of leg. Store parts in a safe place.

1

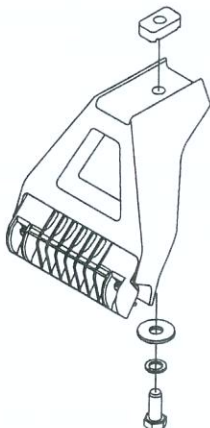

2

Note: When spacer block is to be used on the RL280 leg 3mm must be removed from boss.

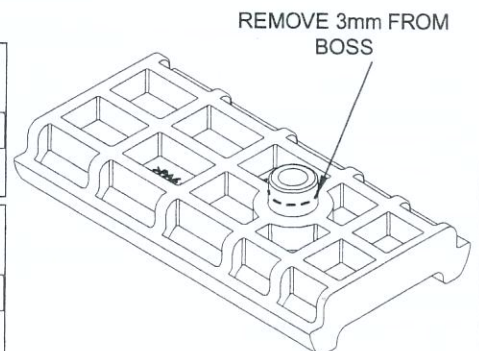
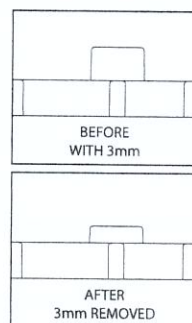

CONTROLLED